

Australian Tipping Systems



ATS SERIES

*LIGHT TRUCK CRANES
WITH HEAVY-DUTY ATTITUDE*



The Dominating Force In Transport Hydraulics



ATS SERIES

LIGHT TRUCK CRANES

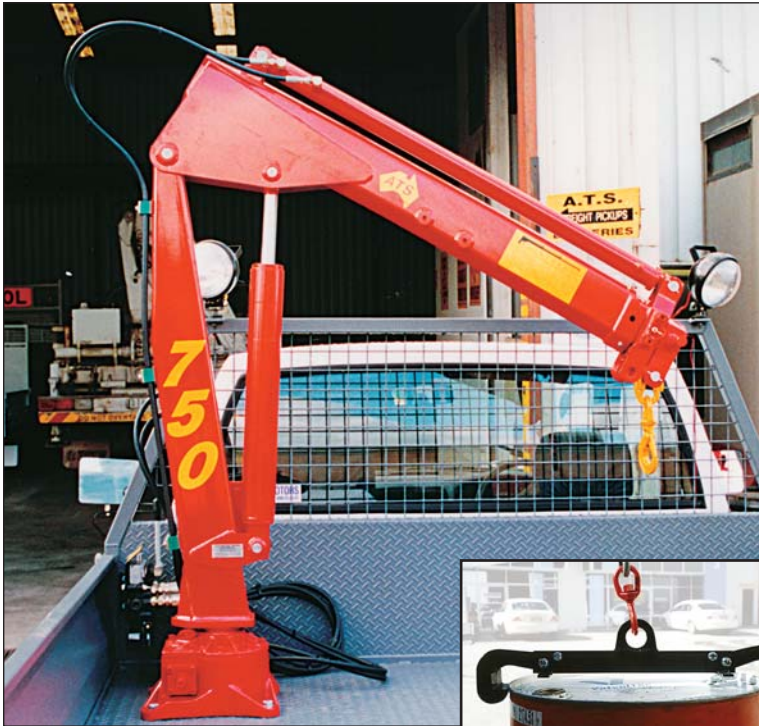

Optional 44 gallon drum attachment

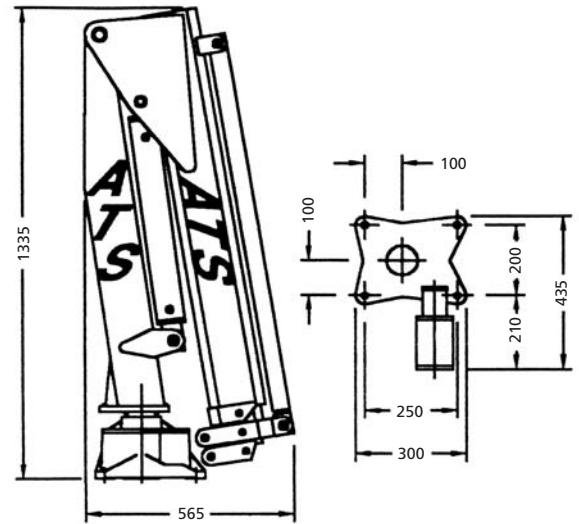

TECHNICAL DATA		750 SERIES	1100 SERIES
LIFTING MOMENT	kNm	7.35	9.8
OUTREACH	m	2.00	2.00
OPTIONAL OUTREACH	m	3.00	3.00
SLEWING ANGLE	Deg	400	400
SLEWING TORQUE	kNm	1.5	1.5
FLOW REQUIREMENT	l/min	4	4
WORKING PRESSURE	bar	145	145
CRANE WEIGHT TYPICAL	kg	158	166

Features:

- Meets applicable Australian Standards
- Chromed cylinder rods
- Teflon lined bushes
- High strength hexagonal boom
- Fully sealed, oil filled base
- Fully proportional control valve
- Easily transferred to new vehicle when updating
- Australian designed and manufactured

Options:



Remote control



P.T.O. Drive



Winch



Hydraulic Stabiliser

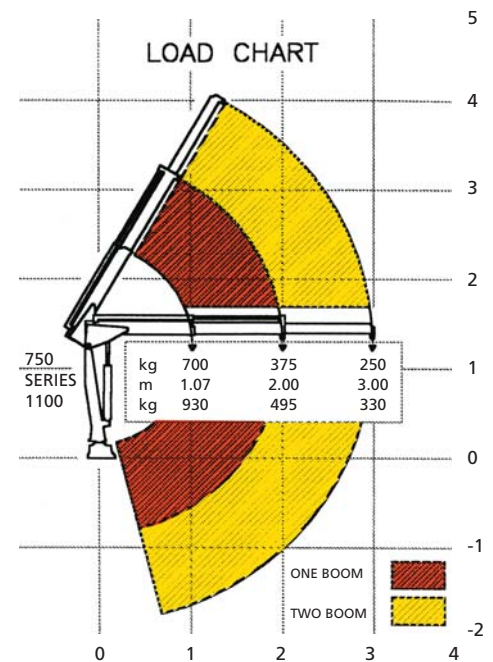

Australian Tipping Systems

Contact ATS now for information on our wide range of Tipping and Hydraulic applications

All specifications subject to change without notice



VIC
Ph: (03) 9872 5188
Fax: (03) 9872 5198

NSW
Ph: (02) 9822 5053
Fax: (02) 9600 8617

QLD
Ph: (07) 3276 8522
Fax: (07) 3276 8533

www.austip.com.au